



KIRLOSKAR PNEUMATIC CO. LTD.

A Kirloskar Group Company

Enriching Lives

KIRLOSKAR RECIPROCATING AIR COMPRESSORS



Modular & Proven Heavy Duty Design | Energy Efficient
Pre-tested for Performance | Ready to use Package

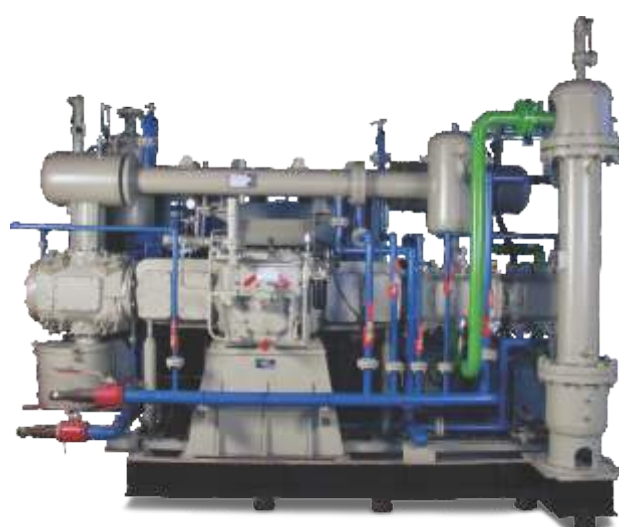

Meeting Your Expectations

Established in the year 1958, Kirloskar Pneumatic Company Limited is a pioneer in Compressed Air and Gas Solutions. Kirloskar Pneumatic Company Limited, a flagship company in Kirloskar group is an IMS Certified company KPCL has grown over the past 50 years by serving the customers with all types of air and gas compressors. The multi-product company has transformed with cutting-edge products and processes to meet the demands and applications.

The company has a strong presence in the global market with customers in more than 40 countries and partners from more than 10 countries. KPCL operates from its Main Office & Factory at Pune with state of the art facilities for Research and Development Manufacturing, Assembly, Testing, Metrology and other business processes.

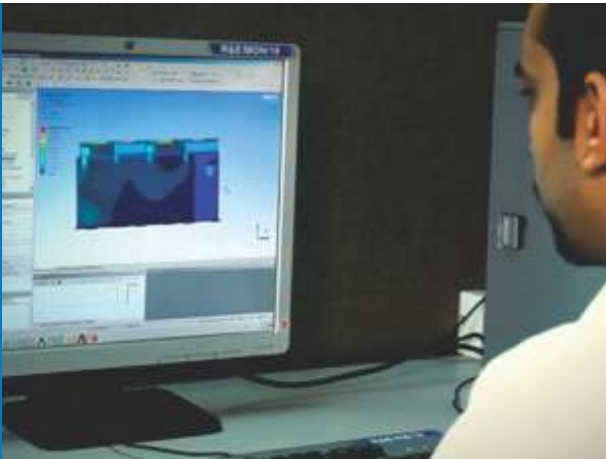

Proven Design & Performance

In house design and engineering centre, analyses every component of the compressor for assured performance. Various softwares like ProE, Ansys, HTRI, Ansys, etc. are used for accurate design and selection of components. Sophisticated analysis softwares provide material properties, which helps understand the material behavior under load conditions. Heavy duty test beds, capable of accommodating multiple compressors at a time are equipped with data monitoring systems to provide real time accurate data. This data is analyzed to improve performance of the compressors.

Addresses Wide Pressure Range
Discharge Pressure: 1 to 400 kg/cm²g

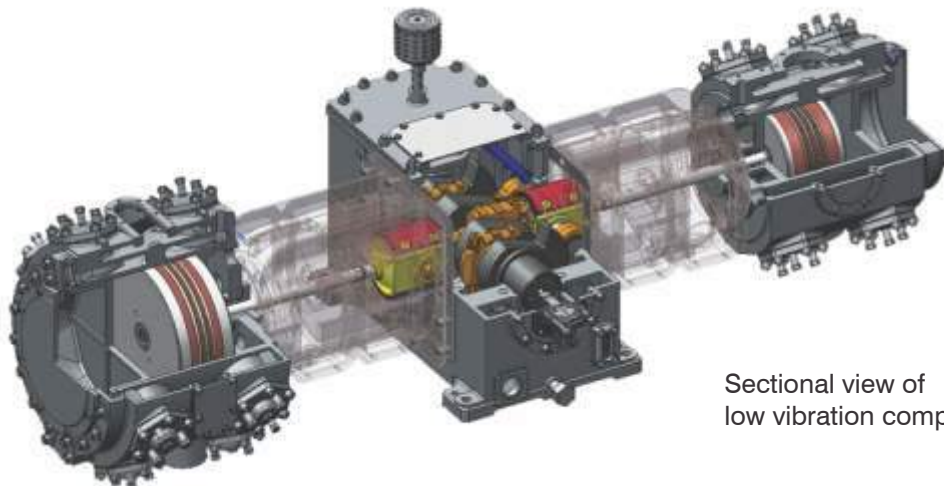

Sectional view of low vibration compressor

Kirloskar Reciprocating Compressors are preferred by various industries for compressed Air & Gas applications.



Steel



Cement & Ready Mix



Food & Beverage



Pet Blowing



Sugar & Co-generation



Oil & Gas/Petrochemical Refinery



Air Separation



Textile



Water & Waste Water Management



Power & Ash Handling



Fertilizer



Chemical



Pharma

State-of-the-art Manufacturing facility



Kirloskar Reciprocating Compressors

100% Oil Free Air

Oil content in air leads to corrosion of tubes and malfunctioning of pneumatic tools. Compressed air from Kirloskar Reciprocating Compressors is free from oil particles thereby extending the life of pneumatic machines. Efficient and wear resistant packing rings isolate oil to the first compartment of the distance piece.

No Foundation Required

Pre-tested Kirloskar Compressors are free from high vibration levels and hence can be placed on skids that are not heavy. Kirloskar LV Compressors are equipped with Anti Vibration Mounts which make them the first choice for raised floor installations.

Complete Packaged Solution

Trouble free installation with Plug & Play type compressors. These are self contained packages with Compressor, radiators, Motor, Air Receiver, Dryer and a highly programmable control system.

Pre-tested for Performance

Each assembly of every Kirloskar Compressor undergoes careful testing in a state of the art In-house Metrology Lab. Completely assembled packages are then tested on specially designed test beds at variable load settings.

Engineering Excellence

Highly qualified dedicated engineering project teams provide the most efficient solutions for compression requirements. Regular technological improvements in our product ensure latest offerings for our Clients.



Endurance

- Reliability and efficiency in adverse conditions
- High altitudes
- High temperatures



Easy To Install

- Ready to install- quick startup
- No special foundations or anti-vibration precautions
- Lower footprint
- Minimal water and electrical connections



Reliable

- Pre tested compressor packages
- Extensive testing for torsional and inertia forces
- Low vibration design
- Sophisticated PLC - control system



Energy Efficient

- Optimum design to deliver maximum flow/kW
- Lower total operating cost
- Lower life cycle cost



Efficient Plate valves

- ➔ Large flow area
- ➔ Special spring protection
- ➔ High efficiency and long service life



Anti-vibration Mounts

- ➔ No foundation required
- ➔ Skid mounted compressor packages
- ➔ Easy field installation
- ➔ Specially designed rubber composite material



Piston and Rider rings

- ➔ Efficient PTFE Piston rings for longer duty cycle
- ➔ Enhanced working life of 8000 hours



Integrated Distance piece

- ➔ Strategically designed Integrated Crosshead housing and Distance piece for a robust construction
- ➔ Efficient oil-scrapper rings ensures zero oil carryover to second compartment



Touch Screen TFT with PLC

- ➔ 7 inch colour TFT
- ➔ Provision for USB data logging
- ➔ Remote monitoring
- ➔ SMS alerts to user

Oil Free Compressors

Single Stage Compressors

Model		Cylinder Dimensions mm			Compressor Speed		Working Pressure		Free Air Delivery	
		Bore		Stroke	RPM		kg/cm2g		m3/min	
		LP	HP		Min	Max	Min	Max	Min	Max
	T-BD-QL	2X385	-	150	550	800	1	4	19.99	39.94
	T-BD-RL	2X470	-	150	550	750	1	2.5	37.09	72.3
HY	1HY2T	185	185	115	400	825	1	4.5	3.27	8.8
	1HY2BIST	215	215	115	400	825	1	4.5	4.93	11.98
	1HY2TERT	250	250	115	400	825	1	4.5	6.89	16.11
HA	1HA2T	2X250	-	150	400	900	1	4	9.06	23.68
	1HA2BIST	2X280	-	150	400	900	1	3.5	11.47	29.76
	1HA2TERT	2X310	-	150	400	900	1	3	14.72	36.84
HB	1HB2BIST	2X450	-	200	350	600	1	3.5	36.23	70.2
	1HB2BISNT	2X500	-	200	350	600	1	3	44.04	85.7
	1HB2TERT	2X560	-	200	350	600	1	2.5	54.25	105.6

Two Stage Compressors

Model		Cylinder Dimensions mm			Compressor Speed		Working Pressure		Free Air Delivery	
		Bore		Stroke	RPM		kg/cm2g		m3/min	
		LP	HP		Min	Max	Min	Max	Min	Max
	T-BTD-MM	255	160	120	450	800	4	10	2.37	4.34
	T-BTD-QM	385	235	150	550	800	5	10	10.22	18.38
	T-BTD-RM	470	290	150	550	750	5	8.5	12.67	22.91
	T-BTD-RH	470	265	150	450	800	10	11.5	18.5	33.01
HY	2HY2T	185	105	115	400	825	6	8	1.92	4.04
	2HY2BIST	215	140	115	400	825	6	8	2.74	5.73
	2HY2TERT	250	140	115	400	825	6	8	3.49	7.3
	2HY2ST	185	105	115	400	825	9	16	1.77	3.91
	2HY2BISST	215	140	115	400	825	9	9.5	2.72	5.64
	2HY2TERST	250	140	115	400	825	9	9	3.47	7.15
HA	2HA2T	250	160	150	400	900	4	8	5.15	11.82
	2HA2BIST	280	160	150	400	900	4	8	6.46	14.86
	2HA2TERT	310	185	150	400	900	4	8	7.79	18.22
HB	2HB2BIST	450	280	200	350	600	4	8	19.48	34
	2HB2BISNT	500	310	200	350	600	4	8	23.51	41.1
	2HB2TERT	560	370	200	350	600	4	7	29.33	51.18
	2HB4BIST	2X450	2X280	200	350	600	4	8	38.97	68
	2HB4BISNT	2X500	2X310	200	350	600	4	8	47.02	82.2
	2HB4TERT	2X560	2X370	200	350	600	4	7	58.66	106.36
	2HB6BIST	3X450	3X280	200	350	600	4	8	58.48	102
	2HB6BISNT	3X500	3X310	200	350	600	4	8	70.53	123.3
	2HB2BISST	2X450	245	200	350	600	9	15	18.7	32.6
	2HB2BISNST	2X500	280	200	350	600	9	15	22.28	39.1
	2HB2TERST	2X560	310	200	350	600	8	13	26.13	46.7
	2HB4BISST	2X450	2X245	200	350	600	9	15	37.39	65.2
	2HB4BISNST	2X500	2X280	200	350	600	9	15	44.57	78.2
	2HB4TERST	2X560	2X310	200	350	600	8	12	52.73	93.4

Oil Free Compressors

Three Stage Compressors

Model	Cylinder Dimensions mm		Compressor Speed		Working Pressure		Free Air Delivery	
	Stroke		RPM		kg/cm ² g		m ³ /min	
			Min	Max	Min	Max	Min	Max
HA	3HA2T	150	400	750	16	40	2.7	8
	3HA2BIST	150	400	750	16	40	5.5	10.3
	3HA2TERT	150	400	750	16	40	2.9	5.6
	3HA4T	150	400	750	16	40	7.1	16
	3HA4BIST	150	400	750	16	40	8.4	16
	3HA4TERT	150	400	750	16	40	13.3	25.7

Four Stage Compressors

Model	Cylinder Dimensions mm		Compressor Speed		Working Pressure		Free Air Delivery	
	Stroke		RPM		kg/cm ² g		m ³ /min	
			Min	Max	Min	Max	Min	Max
HA	4HA2TERT	150	400	750	30	120	3.6	6.6
	4HA4T	150	400	750	30	120	5.3	10
	4HA4BIST	150	400	750	30	120	6.4	12
	4HA4QT	150	400	750	30	120	11.6	17.5
	4HA4PT	150	400	750	30	120	13.3	22
	4HA4TERT	150	400	750	30	120	7.4	14
HB	4HB4BIST	200	375	600	30	120	19.4	31.8
	4HB4BISNT	200	375	600	30	120	25	40.3
	4HB4TERT	200	375	600	30	120	30.7	49.7



Lubricated Compressors

Three Stage Compressors

Model		Cylinder Dimensions mm	Compressor Speed		Working Pressure		Free Air Delivery	
			RPM		kg/cm ² g		m ³ /min	
			Min	Max	Min	Max	Min	Max
HA	3HA2	150	400	750	16	40	2.8	8.2
	3HA2BIS	150	400	750	16	40	5.7	10.6
	3HA2TER	150	400	750	16	40	3	5.8
	3HA4	150	400	750	16	40	7.3	16.5
	3HA4BIS	150	400	750	16	40	8.7	16.5
	3HA4TER	150	400	750	16	40	13.8	26.5

Four Stage Compressors

Model		Cylinder Dimensions mm	Compressor Speed		Working Pressure		Free Air Delivery	
			RPM		kg/cm ² g		m ³ /min	
			Min	Max	Min	Max	Min	Max
HA	4HA2TER	150	400	750	30	120	3.6	6.8
	4HA4	150	400	750	30	120	5.5	10.3
	4HA4BIS	150	400	750	30	120	6.6	12.3
	4HA4Q	150	400	750	30	120	11.9	18
	4HA4P	150	400	750	30	120	13.3	22
	4HA4TER	150	400	750	30	120	7.4	14
HB	4HB4BIS	200	375	600	30	120	19.4	31.8
	4HB4BISN	200	375	600	30	120	25	40.3
	4HB4TER	200	375	600	30	120	30.7	49.7

Five Stage Compressors

Model		Cylinder Dimensions mm	Compressor Speed		Working Pressure		Free Air Delivery	
			RPM		kg/cm ² g		m ³ /min	
			Min	Max	Min	Max	Min	Max
HA	5HA4	150	400	750	120	250	3.8	8.3
	5HA4BIS	150	400	750	120	250	4.6	10
	5HA6	150	400	750	120	250	4.8	10.5
HB	5HB4BIS	200	375	600	120	250	18.6	39.7

Six Stage Compressors

Model		Cylinder Dimensions mm	Compressor Speed		Working Pressure		Free Air Delivery	
			RPM		kg/cm ² g		m ³ /min	
			Min	Max	Min	Max	Min	Max
HA	6HA4	150	400	600	250	400	2.4	4

Global Footprint



**We Ensure Prompt Service & Support
with over 60+ Dealers in India**



Enriching Lives

KIRLOSKAR PNEUMATIC CO. LTD.

A Kirloskar Group Company

REGD. OFFICE & WORKS : PUNE : Hadapsar Industrial Estate, PUNE 411 013.

Ph : 020 - 26870133 / 26727000 Fax : 020 - 26870297 / 26870634. Email : acdmktg@kpcl.net

BRANCH	TELEPHONE	FAX	E-MAIL
MUMBAI : 1002, 10th Floor, Vikas Centre, Dr. C.G. Road, Opp. Bombay Presidency Golf Club, Chembur (East), Mumbai 400 074	022 - 61511234	022 - 25181313	kpclmumacd@kpcl.net
DELHI : 607, Manjusha Building, 57 Nehru Place, New Delhi 110 019	011 - 26289962, 26421346	011 - 26429685	kpclidelacd@kpcl.net
BANGALURU : NO 102, 1st Floor, Andree Capitol, 8/1 KH Road, Bangaluru 560 027	080 - 22270029, 22270079	080 - 22270045	ccsblr@kpcl.net
CHENNAI : 1st Floor, Elcanso Complex No. 10, Cosa Major Road, Egmore, Chennai 600 008	044 - 28193066, 28190436, 28192092, 30910143/0144	044 - 28194937	kpclchnacd@kpcl.net
HYDERABAD : 3-5-907, 403-404, Mahavir Lok, Himayatnagar Hyderabad 500 029	040 - 23260743, 23260746,	040 - 23260171	hyd2_kpclhyd@sancharnet.in
KOLKATA : 15 GaneshChandra Avenue, 9th Floor, Kolkatta 700 013	033-22119080, 22119081, 22111905	033 - 22365586, 22116948	kpclcal@cal2.vsnl.net.in
VADODARA : Chi Chi Tower, A, Killol Children Hospital Lane, Tana Apartment, Ellora Park, Subhanpura, Vadodara 390007	0265 - 2284604, 2284605, 2284606, 3096787	0265 - 2280095	kpclbrd@gmail.com



An IMS Certified Company

www.kirloskarkpcl.com

CIN: L29120PN1974PLC110307

